

TABLE OF CONTENTS

1. INTRODUCTION
2. DEFINITIONS APPLICABLE TO THESE STANDARDS
3. PROHIBITION OF INSTALLATION OF SEWAGE DISPOSAL SYSTEMS
4. PLANS/PERMITS REQUIRED TO CONSTRUCT OR OPERATE
5. APPROVAL OF CONSTRUCTION REQUIRED
6. DETERMINING MINIMUM DESIGN SEWAGE FLOW RATES
7. DETERMINING TYPE OF SEWAGE DISPOSAL SYSTEM
8. COMMUNITY SEWERAGE SYSTEMS
9. ON-LOT SEWAGE TREATMENT SYSTEMS
10. CONDOMINIUMS, CO-OPS AND TOWN HOUSES
11. COVENANTS AND RESTRICTIONS
12. LOCATION OF SEWAGE DISPOSAL SYSTEMS
13. SUBSOIL AND GROUNDWATER CONDITIONS
14. APPROVAL OF CONSTRUCTION COMPONENTS REQUIRED
15. SEPTIC TANKS
16. GREASE TRAPS
17. LEACHING POOLS
18. MANHOLES
19. GRAVITY SEWER LINES
20. SEPARATION OF WATER AND SEWER LINES
21. FINAL GRADING AND BACKFILLING
22. SEWAGE LIFT STATIONS
23. VARIANCES
24. APPROVAL BY THE COMMISSIONER OF HEALTH SERVICES
25. SEWAGE DESIGN FLOWS - ADDENDUM

STANDARDS FOR APPROVAL OF PLANS AND CONSTRUCTION FOR SEWAGE DISPOSAL SYSTEMS FOR OTHER THAN SINGLE FAMILY RESIDENCES

1. INTRODUCTION

These are Standards for the Suffolk County Department of Health Services for the Administration of Section 502, of Article 5 (Sewage Disposal), Sections 607-609 of Article 6 and Sections 705, 706, 709-716 of Article 7 of the Suffolk County Sanitary Code.

The purpose of these standards is to provide a means for achieving protection of the groundwater from excessive contaminant loading and to assure a safe, sanitary means of disposing wastewater. Diseases such as infectious hepatitis, typhoid fever and dysentery can be transmitted by water, food, insects, pets, and toys contaminated by human waste. Properly designed, maintained and operated sewage disposal systems minimize the possibility of disease transmission and the potential for contamination of ground and surface waters.

The information presented in these standards applies to commercial, industrial, multiple residential or other buildings and only addresses sewage as herein defined. Other solid, liquid or gaseous emissions or discharges are subject to a separate review and approval by the department. For details relating to single family residences, refer to **Standards for Approval of Plans and Construction for Subsurface Sewage Disposal Systems for Single Family Residences**.

2. DEFINITIONS APPLICABLE TO THESE STANDARDS

Adjusted Gross Land Area - Gross land area of a parcel minus area of regulated freshwater or tidal wetlands and ponds or other underwater lands.

Backfill - 1) The operation of refilling an excavation, usually after some structure or pipe has been placed therein; 2) the material placed in an excavation in the process of backfilling.

Cleanout - A device brought to grade to facilitate cleaning of sewer lines.

Commercial Projects - Restaurants, office buildings, nursing homes, hospitals, warehouses or any other type project not considered residential in nature.

Community Sewerage System - A system utilized for the collection and disposal of sewage, or other waste of a liquid nature, including the various devices for the treatment of such wastes, serving more than one parcel, or a condominium project. A community sewerage system requires acceptance by the Suffolk County Sewer Agency. On-lot sewage treatment systems are not community sewerage systems.

Conventional Subsurface Sewage Disposal System - Septic tank(s) and subsurface leaching facilities. Conventional Subsurface Sewage Disposal Systems are not On-Lot Sewage Treatment Systems or Community Sewerage Systems.

Department - The Suffolk County Department of Health Services.

Design Sewage Flow - The volume of sewage to be used for the purpose of designing the size and/or capacity of the sewage disposal system.

Grease Trap - A watertight chamber which promotes the separation of fats and greases.

Groundwater - The zone of saturation below the established water table.

Groundwater Management Zone - Any one of the areas delineated in Suffolk County by the "Long Island Comprehensive Waste Treatment Management Plan (L.I. 208 Study)," as revised by the "Long Island Groundwater Management Plan", and subsequent revisions adopted by the Suffolk County Board of Health identifying differences in regional hydrogeologic and groundwater quality conditions. The boundaries of the Groundwater Management Zones are set forth on a map adopted by the Board filed in the Office of the Commissioner of Health in Hauppauge, New York.

Groundwater Monitoring Well - A small diameter well introduced into a particular aquifer for the purpose of obtaining samples of the groundwater for chemical analysis.

Hydraulic Loading - The daily volume of sewage generated.

Leaching Area - The sidewall area in a leaching pool below the inlet pipe or the bottom surface area of a recharge bed.

Leaching Pool - A covered pit with perforated concrete wall through which septic tank effluent will infiltrate the surrounding soil.

Manhole - A watertight chamber used for smooth redirection of sewage flow and/or providing access to sewer lines.

Modified Subsurface Sewage Disposal System (Denitrification) - An on-lot sewage treatment system which includes non-mechanical processes (except for sewage lifting) to remove nitrogen from sewage in excess of that removed in a conventional subsurface sewage disposal system.

Multiple Residential Units - All residential construction other than detached single family housing units. Examples include two family houses, single family units with accessory apartments (mother- daughter), apartment complexes, condominiums, homeowners' associations (HOA's), co-ops, hotels, motels, mobile homes, or other similar type arrangements.

Occupancy Rating - The maximum number of persons permitted to occupy an establishment as determined by the appropriate agency.

On-Lot Sewage Treatment System - A system located on the same lot as the building(s) it serves which provides treatment that includes removal of nitrogen from sewage in excess of that removed in a conventional subsurface sewage disposal system. Processes are of a type and design acceptable to the Department.

Perched Groundwater - Groundwater which is separated from the main body of groundwater by an aquiclude (e.g. a clay lens).

Population Density Equivalent - An expression of the quantity of domestic sewage in terms of the calculated population per unit area which would normally contribute the same amount of sewage.

Recharge Bed - A designated area exposed to the atmosphere where treated wastewater is distributed over a designed disposal area for the purpose of infiltrating the surrounding soil.

Septic Tank - A watertight chamber used for the settling, stabilizing and anaerobic decomposition of sewage.

Sewage - Water-carried wastes from residences, institutions, businesses, commercial and industrial buildings and establishments or a combination thereof, together with such ground, surface, and storm water as may inadvertently be present. The admixture of industrial wastes or other wastes shall not be considered sewage for purposes of these standards except where otherwise indicated. "Industrial wastes" and "other wastes" have the meaning set out in Environmental Conservation Law Sections 17-0105(5) and (6).

Sewage Disposal System - Any plumbing or conveyances which result in or are capable of resulting in a discharge of sewage. This includes, but is not limited to, septic tanks, leaching pools, sumps, tile fields, holding tanks, treatment works, outfalls and connecting piping. The term may also refer to a part of a larger disposal system.

Sewer Line - A pipe designed to convey sewage.

Sewer System (also referred to as sewerage system, sewage collection system, public sanitary sewer, municipal sewage disposal system, privately owned communal sewerage system, and communal sewage disposal system) - Pipe lines, conduits, pumping stations, and force mains, and all other constructions, devices, and appliances appurtenant thereto, used for conducting sewage, to a point of ultimate disposal.

Treatment Works (also referred to as sewage treatment plant or S.T.P.) - A facility designed for the purpose of removing certain constituents from sewage by mechanical, chemical, and biological means and disposing of sewage.

3. PROHIBITION OF INSTALLATION OF SEWAGE DISPOSAL SYSTEMS

The installation of a sewage disposal system(s) is prohibited by the Suffolk County Sanitary Code unless a permit to construct has been issued by the Commissioner.

4. PLANS/PERMITS REQUIRED TO CONSTRUCT OR OPERATE

Written approval of plans is required before start of construction. Plans shall be prepared by a licensed engineer or architect and shall conform to guidelines issued by the department. For projects involving wetlands and/or surface waters, see also Appendix D. These plans, once approved and signed by an authorized representative of the department, become a permit to construct a disposal system and can be taken to the local building department to obtain a building permit.

Permits are required for all new construction and additions and for changes in use of existing buildings and renovations which may affect sanitary waste flows.

In the case of a building or buildings discharging to a treatment works, a permit to construct, in certificate form, is needed to establish Department approval of the design of the treatment works.

A separate permit to operate is also required in the case of an on-lot sewage treatment system or a community sewerage system. Additional submission instructions for community sewerage systems are presented in Appendix B.

A SPDES permit issued by the New York State Department of Environmental Conservation or its agent is required for all discharges of sanitary waste to groundwater where design flows are 1,000 gallons per day or greater.

Permits from other agencies, where such permits may affect placement of the sewage disposal systems, shall be submitted to the department prior to the department's issuance of a permit to construct. Such permits include but are not limited to wetlands or natural resources permits from the New York State Department of Environmental Conservation, the Army Corps of Engineers, and/or the appropriate local regulatory authority (e.g. delegated agents for NYSECL Articles 15, 24, 25, Wild, Scenic & Recreational Rivers; Town natural resources permits, etc.).

Refer also to **Suffolk County Department of Health Services Submission Requirements for Other Than Single Family Residential Construction - Bulletin WWM-003** for plans submission instructions.

5. APPROVAL OF CONSTRUCTION REQUIRED

Sewage disposal systems constructed in Suffolk County shall conform to standards herein approved by the Commissioner of the Suffolk County Department of Health Services.

Prior to backfilling, installed subsurface structures and sewers shall be inspected and authorized for backfilling by a representative of the department. The department shall be notified at least forty-eight (48) hours in advance of scheduled backfilling.

These requirements will not be waived by the Department. Backfilling prior to Department inspection will result in an order by the Commissioner to remove all backfill for inspection. No approval or permit will be made or issued by the Department unless there is compliance with these requirements.

Approval of completed construction will be granted to the applicant on "as built" plans which are to be submitted after the final satisfactory field inspection is completed. These plans are to include accurate measurements from permanent, fixed reference points to each component of the sewage disposal system and the water supply well or public water service line. Plans are to be signed and sealed by a licensed professional engineer or architect except a licensed surveyor may sign for conventional subsurface sewage disposal systems only. In some cases the department also requires separate certification of construction by a licensed professional engineer or architect (see appendices). Occupancy of a building is prohibited without the final approval of the department.

6. DETERMINING MINIMUM DESIGN SEWAGE FLOW RATES

Minimum design sewage flow rates for a project are derived from occupancy ratings and/or from the following table:

<u>STRUCTURE USE</u>	<u>DESIGN SEWAGE FLOW RATE</u>
Single Family Equivalent	300 gals. per day (gpd)
Two Family Residence	600 gpd
Accessory Apartment to a single - family unit (up to 400 sq. ft)	150 gpd

Motels with kitchenettes, apartments, condos, HOA's, mobile homes, trailers, co-ops, etc. up to 600 sq. ft. of gross floor area.	150 gpd/unit
" " 601 - 1200 sq. ft. of gross floor area	225 gpd/unit
" " greater than 1200 sq. ft. of gross floor area	300 gpd/unit
Motel unit less than 400 sq. ft.	100 gpd/unit
Motel unit greater than 400 sq. ft.	150 gpd/unit
PRC unit less than 600 sq. ft.	100 gpd/unit
PRC unit greater than 600 sq. ft.	150 gpd/unit
Boarding School/Rooming House	75 gpd capita
Tourist Camp	60 gpd/site
General Industrial Space	0.04 gpd/sf gr. floor area
Non-Medical Office Space	0.06 gpd/sf gr. floor area
Theater	3 gpd/seat
Bowling alley, tennis court	100 gpd/crt - alley + food
Day School	5 gpd/capita + food
Spa, Country Club	0.30 gpd/sf gr. floor area
Medical Arts	0.10 gpd/sf gr. floor area
Hospital	300 gpd/bed
Nursing Home	150 gpd/bed
Proprietary Home	110 gpd/bed
Eating Place (16 seat minimum or any size with dishwasher)	30 gpd/seat
Wet Store - Food processing	0.15 gpd/sf gr. floor area
Wet Store no food (barber shop, etc.)	0.10 gpd/sf gr. floor area

Dry Store (no process water discharge)	0.03 gpd/sf gr. floor area
Bar, Tavern, Disco	15 gpd/occupant + food
Catering Hall	7.50 gpd/capita
Market	0.05 gpd/sf gr. floor area
Church	1.50 gpd/capita
Bath House	5 gpd/occ. + 5gpd/shower
Cafeteria (integral to an office or industrial building)	2.50 gpd/capita
Other	Consult the Department

For mixed type buildings such as office/warehouse a proportionate flow criteria should be applied to each building section. For additional flow criteria and breakdowns of sanitary and kitchen flows, see the attached addendum.

7. DETERMINING TYPE OF SEWAGE DISPOSAL SYSTEM

A population density equivalent estimate must be made in order to determine the type of sewage disposal system required for a project. The population density equivalent is compared to the design sewage flow for the project. If your project's design sewage flow is less than the population density equivalent, then conventional subsurface sewage disposal systems may be acceptable. There are two alternative acceptable methods for determining population density equivalent, a calculation or a yield map method.

A. MULTIPLE RESIDENTIAL UNITS

1. CALCULATION METHOD

In order to determine population density equivalent, a calculation is made which accounts for roads, recharge basins, and other appurtenances as would normally be necessary to develop single family lots on the site. Population density equivalent is calculated as seventy five percent (75%) of adjusted gross land area in square feet divided by 20,000 (40,000 in groundwater management zones III, V, or VI, or where a community water supply is not being provided), and multiplied by 300. The resultant figure is the population density equivalent expressed in gallons per day.

Prior to determining adjusted gross land area, accurate boundaries for wetlands, surface waters and flood zones shall be delineated and shown on official surveys and site plans. See Appendix D for boundary delineation requirements.

2. YIELD MAP METHOD

A map illustrating the location of building lots that meets the above stated restrictions regarding recharge basins, roads, etc. may be submitted for review and lot yield determination by the department. Accurate boundaries for wetlands, surface waters and flood zones shall be delineated and shown on official surveys

and site plans. See Appendix D for boundary delineation requirements. Wetlands or flood zones may be shown as part of the lots on a yield map. However, for all lots it must be demonstrated that the location of individual sanitary systems meet distance or setback requirements to regulated wetlands, surface waters and flood zones as provided by these standards or by appropriate agencies having jurisdiction.

All lots shown on the yield map must be at least 20,000 sq. ft. in area (40,000 sq. ft. in groundwater management zones III, V, or VI, or where a community water supply is not being provided). Population density equivalent in gallons per day equals the lot yield multiplied by 300 gallons per day per lot.

If the project design sewage flow rate exceeds the population density equivalent, a community sewerage system or on-lot sewage treatment system as applicable is required.

B. COMMERCIAL PROJECTS

1. CALCULATION METHOD

Population density equivalent is calculated by multiplying the adjusted gross lot area in acres (43,560 sq. ft.) by 600 gallons per day per acre (300 gallons per day per acre of lot area in Groundwater Management Zones III, V, or VI, or where a community water supply is not being provided). Prior to determining adjusted gross lot area, accurate boundaries for wetlands, surface waters and flood zones shall be delineated and shown on official surveys and site plans. See Appendix D for boundary delineation requirements.

2. YIELD MAP METHOD

A map illustrating the location of building lots that meets the above stated restrictions regarding recharge basins, roads, etc. may be submitted for review and lot yield determination by the department. Accurate boundaries for wetlands, surface waters and flood zones shall be delineated and shown on official surveys and site plans. See Appendix D for boundary delineation requirements.

Wetlands or flood zones may be shown as part of the lots on a yield map. However, for all lots it must be demonstrated that the location of individual sanitary systems meet distance or setback requirements to regulated wetlands, surface waters and flood zones as provided by these standards or by appropriate agencies having jurisdiction.

All lots shown on the yield map must be at least 20,000 sq. ft. in area (40,000 sq. ft. in Groundwater Management Zones III, V, or VI, or where a community water supply is not being provided). Population density equivalent in gallons per day equals the lot yield multiplied by 300 gallons per day per lot.

Kitchen wastes (as shown in the attached Addendum) from establishments with food processing may be excluded from the design flow when comparing to population density equivalent. If the project design sanitary flow rate (sewage flow rate minus kitchen wastes) exceeds the population density equivalent, a community sewerage system or on-lot sewage treatment system as applicable is required except where the project design sewage flow (including kitchen wastes) does not exceed 300 gpd.

In cases where a community sewerage system or on-lot sewage treatment system is not required, a conventional subsurface sewage disposal system may be approved provided all other design standards can be met (see Section 8).

8. COMMUNITY SEWERAGE SYSTEMS

A community sewerage system is required:

- A. when the site to be developed has an approved community sewerage system available and accessible as determined by the department;
- B. for a building or buildings when the population density equivalent exceeds the limits set forth in Article 6 of the Suffolk County Sanitary Code. On-lot sewage treatment systems are allowed in some cases, see below;
- C. when the existing subsoils contain meadow mat, bog, silts, clays, or other impervious material which extends below the groundwater table and/or groundwater conditions are not conducive to the proper functioning of subsurface sewage disposal systems or on-lot sewage treatment systems.

Community sewerage systems include a sewage collection system, treatment works, and a sewage disposal system and require acceptance by the Suffolk County Sewer Agency. Design of these systems is covered in the NYSDEC Standards for Waste Treatment Works and the GLUMRB Recommended Standards for Sewage Works (**Ten States Standards**). Facilities shall be capable of producing a discharge of 10mg/l total nitrogen or less in the effluent stream. Community sewerage systems may accept industrial or other wastes in accordance with applicable permits issued by the authority having jurisdiction. Applicants should consult the department prior to submission of designs of community sewerage systems. Additional standards for construction of treatment works and sewer pipes can be found in Appendix B and E respectively.

9. ON-LOT SEWAGE TREATMENT SYSTEMS

On-lot sewage treatment systems are acceptable for construction projects on other than single family or two family residentially zoned single parcels provided with public water not part of a subdivision or development currently proposed or previously approved by the department. Examples of projects for which on-lot sewage treatment systems are acceptable include apartments, hotels, motels, restaurants, office buildings and industrial buildings.

On-lot sewage treatment systems shall be of a type and design acceptable to the department. These can be classified into three categories:

A. TREATMENT WORKS

A treatment works capable of producing a discharge of 10 mg/l total nitrogen or less in the effluent stream. Applicable design standards are found in **Ten States Standards** and in Appendix B.

B. MODIFIED SUBSURFACE SEWAGE DISPOSAL SYSTEM (DENITRIFICATION)

A modified subsurface sewage disposal system (denitrification) capable of producing a discharge of 10 mg/l total nitrogen or less in the effluent stream is acceptable where the total design sewage flow (kitchen and sanitary, as determined by section above) does not exceed 15,000 gallons per day. However, where the total design sewage flow exceeds 1,000 gpd, the NYSDEC must review the proposed system design and issue a SPDES permit for the facility before this department can issue approval to construct.

C. INNOVATIVE TREATMENT SYSTEMS

Innovative treatment systems will be evaluated by the Department on a case by case basis. An innovative treatment system shall be capable of producing a discharge of 10 mg/l total nitrogen or less in the effluent stream. The department may accept these systems where the total design sewage flow (kitchen and sanitary, as determined by section above) does not exceed 15,000 gpd. However, where the total design sewage flow exceeds 1,000 gpd, the NYSDEC must review the proposed system design and issue a SPDES permit for the facility before this department can issue approval to construct.

NOTE: Sections B and C above have been modified since February 5, 1988 to conform to current requirements of NYSDEC.

10. CONDOMINIUMS, CO-OPS AND TOWN HOUSES

Condominiums and Town House projects differ in that condominiums and co-ops remain as a single parcel while a Town House project or Homeowner's Association (HOA) become subdivisions of land that includes common areas. For purposes of sewage disposal both are handled alike in that projects with a design sewage flow less than population density equivalent may utilize conventional subsurface sewage disposal systems provided that the projects otherwise comply with section of these standards.

Projects with design sewage flow larger than population density equivalent require a community sewerage system and acceptance by the Suffolk County Sewer Agency although such community sewerage system may be located in the commonly owned area of the project.

Projects with a design sewage flow rate of 30,000 gpd or greater for which conventional subsurface sewage disposal systems are acceptable shall design separate disposal system clusters or individual disposal systems to be located at the discretion of the Department. Other additional or different conditions as determined by SPDES permit requirements or SEQRA may also apply. The applicant must demonstrate that NYSDEC groundwater standards will not be contravened.

11. COVENANTS AND RESTRICTIONS

Restrictive covenants may be required when submitting sewage disposal plans. Covenant restrictions are applied on lots located in deep recharge or water supply sensitive areas and serve as notice regarding storage restrictions for toxic or hazardous materials or changes in use or occupancy. Other covenants restricting sanitary waste flows may be required where the Department determines that change in use could result in violation of approval conditions or when approval is contingent upon the applicant performing a future action. For further information refer to Articles 6, 7 and 12 of the Suffolk County Sanitary Code.

12. LOCATION OF SEWAGE DISPOSAL SYSTEMS

This and following sections apply generally to all treatment or disposal systems in Suffolk County.

A. GENERAL REQUIREMENTS

Conventional subsurface sewage disposal systems and on-lot sewage treatment systems shall be located on land owned in fee by the applicant. Exceptions on a case by case basis may be made where the disposal system is located in an easement area. Approval will not be granted for any sewage disposal system located in or under any part of a building or public road. Adequate access shall be maintained to the sewage disposal system to allow for maintenance, modification, and monitoring. Adequate area shall be available to allow for a minimum of fifty percent expansion of the leaching system. Deepening the basic system is not permitted in lieu of this expansion area. The table below shows the minimum distances which shall be maintained between sewage disposal systems and other items.

TABLE OF MINIMUM SEPARATION DISTANCES FROM:

	Septic Tank	Leaching Pool ³	Sewer Line
Building with Cellar	10'	10'	--
Building on Slab	5'	10'	--
Water Service Line	10'	10'	10' ⁴
Surface Water	75'	100'	50'
Public Water Well ²	200'	200'	50'
Private Well ¹	100'	150'	50'
Storm Drains	20'	20'	10'
Property Lines	5'	10'	10'
Swimming Pool - in ground	20'	20'	5'
Top of Embankment or Steep Slope	25'	25'	25'

- ¹ Increased distance between leaching pools and private wells may be required based upon the depth of the well(s) involved and the direction of groundwater flow. Refer to **Standards For The Design Of Individual Water Supply Systems**. Discharges from treatment works shall be located downgradient of the well or out of the groundwater flow path towards the well. **Precise groundwater flow direction measurements may be required.**
- ² Significant discharges (generally greater than 5000 gpd or those in close proximity to wells) will require a separate site review. See below.
- ³ These distances also apply to nitrification fields. See Appendix A. Leaching pools for treatment works have different distance requirements. Shallow recharge beds may be allowed for treatment works discharges. See Appendix B for distance requirements for recharge beds or leaching pools associated with treatment works.
- ⁴ Water (pressure) and sewer lines may be in the same trench if the water line is placed on an undisturbed bench or shelf so that the bottom of the water main is at least 18 inches higher than the top of the sewer and the sewer is not subject to settling, vibration, superimposed loads, or frost action.

Depending on a groundwater impact analysis, conventional subsurface sewage disposal systems for multi-family residential attached units (condominiums, cooperatives, etc.) may be clustered or combined to provide for greater disposal efficiency. Disposal system clusters shall be located to allow for maintenance, modification, and expansion. A single disposal system for an entire project may be acceptable, at the discretion of the department, depending upon individual site conditions.

B. WETLANDS, SURFACE WATERS, OTHER SITE SPECIFIC CONSIDERATIONS

To protect the public water supply and the benefits that freshwater wetlands, tidal wetlands, ponds, streams and other surface waters provide, all projects within 1500 feet of a public water supply well or projects within 300 feet of regulated wetlands or surface waters will undergo a separate site review. The following criteria apply to these sites:

1. Sewage disposal systems shall be located to maximize distances to public water supply wells. If the department determines that insufficient distance exists to protect the well, further treatment may be required.
2. Sewage disposal systems shall be located so as to maximize distances to freshwater wetlands, tidal wetlands, ponds, streams, and other surface waters, provided that the criteria in B.1. above are satisfied. In no case may septic tanks, sewer lines, leaching pools or recharge beds be placed closer than 100 feet from the boundaries of regulated freshwater wetlands, regulated tidal wetlands, ponds, streams, or other surface waters.
3. Boundaries of wetlands, surface water and flood zones must be shown accurately on surveys and site plans. Wetlands are not regulated directly by the department, only through standards and regulations of NYSDEC, NYSDOH, and various other government agencies.

13. SUBSOIL AND GROUNDWATER CONDITIONS

- A. Subsoil conditions shall be shown on the plans. The nature of the soil shall be determined by excavation of one or more test holes at the site of the proposed installation. The test hole shall be carried to a depth of six feet in excess of the proposed leaching pool bottom or, in the case of unusual soil, until a strata of six feet of virgin Long Island sand and gravel is encountered. The test holes shall be a minimum of seventeen feet deep or six feet into groundwater. Grade elevation at the test hole shall be indicated on the plans. The architect or engineer, in adding this information to the plan submitted, is considered as certifying the results. Test holes listed as "by others" are unacceptable unless independently certified by a licensed professional engineer, architect, or land surveyor. Test holes undocumented as to time and location of test are not acceptable on the surveys. Additional test holes witnessed by a representative of the Department may be required prior to approval to construct in areas of unusually poor soils or where data on record with the Department indicates conditions different than the test hole data listed on the plans.
- B. Groundwater elevation, if encountered, shall be shown on soil test logs submitted on plans. In areas subject to tidal action, groundwater elevations shall be measured at mean high tide and be so noted on plans.

- C. In cases where groundwater elevation is less than six feet below surface elevation a grading plan is required to be shown on the plans. The grading plan shall indicate plan and profile views of the disposal system, the building first floor and the waste pipe invert respectively and final grade elevation. The plan view shall indicate final grade by showing one-foot contour lines for at least twenty feet from the leaching system.
- D. In the case of unusual soil and/or groundwater conditions, inspection of the excavation by a representative of the department is required prior to the installation of the leaching pool.

14. APPROVAL OF CONSTRUCTION COMPONENTS REQUIRED

All components used in the sewage disposal system shall be approved prior to use. Manufacturer's plans shall be on file with this department. All materials used in manufacture shall be identified and have the identification visible at the time of inspection. The National Sanitation Foundation, The American Society of Testing and Materials and/or The American Water Works Association approval(s) shall be used as a guideline in reviewing materials of construction for approval by the department.

15. SEPTIC TANKS

The minimum size septic tank shall be 900 gallons.

A. RECTANGULAR SEPTIC TANKS

1. Septic tanks shall be designed to hold two full days' design flow of sewage and be constructed of reinforced concrete. A typical design is shown in Figure 1.
2. The septic tank shall be installed on undisturbed soil.
3. Septic tanks greater than 900 gallon capacity shall be divided into two compartments, the inlet compartment to have 50-75 percent of the total capacity. The traverse wall separating compartments shall extend from the bottom to at least 6 inches above the liquid level and be constructed of reinforced precast concrete.
4. The opening in the traverse wall shall be 8 inches in height and at least 24 inches wide. The center of the opening shall be 18 inches below the liquid level. There shall be a minimum 4 inch air gap at the top of the traverse wall.
5. The outlet pipe(s) from the tank shall be provided with a drop 'T' extending eighteen inches into the liquid. The outlet shall be located at the maximum possible distance from the inlet.
6. The outlet invert(s) shall be six inches below the inlet invert and between 4 feet and 7 feet above the tank bottom.
7. There shall be a 1 foot air space measured from the outlet invert(s) to the bottom of the tank cover.
8. All outlets from the septic tank shall be set at the same elevation.
9. The top of the septic tank may not be located greater than 2.5 feet or less than 1 foot below final grade.

10. Traffic bearing tops shall be used. There shall be an opening with a minimum diameter of 20 inches provided for each compartment. The opening(s) shall be located over the inlet and outlet pipes. A watertight and insect-proof heavy-duty cast-iron cover shall be installed at grade over each opening. Chimneys may be used for the purpose of bringing the cast-iron covers to grade. The chimney shall be of reinforced precast concrete at least 24 inches in diameter and shall not exceed 2 feet in height.

B . CYLINDRICAL SEPTIC TANKS

In lieu of a rectangular septic tank, a cylindrical tank (see Figures 2 and 3) that complies with the following additional specifications may be utilized:

1. Tops may be fabricated as either traffic bearing slabs or domes. When domes are used, the septic tank inlet and outlet shall be located within the vertical sidewall and not within the dome.
2. Tanks constructed of 8 foot diameter solid rings shall not exceed 5 feet liquid depth. Tanks constructed of 10 foot diameter rings shall not exceed 6 feet liquid depth. Tanks constructed of 12 foot diameter rings shall not exceed 7 feet liquid depth.
3. Tanks may not be fabricated from rings greater than 12 feet in diameter.
4. When septic tanks are constructed of three or more solid rings, they shall be placed on a common reinforced concrete slab at least 6 inches thick.
5. When septic tanks are constructed of two or more rings, all compartments shall be connected by utilizing three 8" diameter pipes placed such that the center line of the pipes is 18 inches below the operating liquid level of the tank.

16. GREASE TRAPS

At any restaurant or food preparation establishment, a grease trap (Figure 4) for the kitchen or food preparation area is considered as part of the equipment required to obtain a permanent permit to operate a food establishment pursuant to Article 13 of the Suffolk County Sanitary Code. The grease trap shall be placed outside the building preceding the septic tank or sewer lateral. The grease trap shall be a monolithic unit fabricated of precast concrete. Traffic bearing tops shall be used. Tops shall be a minimum of 1 foot and a maximum of 2.5 feet below grade. There shall be an opening with a minimum diameter of 20 inches provided over the inlet and outlet. A watertight and insect-proof cast-iron cover shall be installed at grade over each opening. Chimneys may be used for the purpose of bringing the cast-iron covers to grade. The chimney shall be of reinforced precast concrete at least 24 inches in diameter and shall not exceed 2 feet in height.

The outlet shall be located at the maximum possible distance from the inlet. To determine grease trap capacity, refer to the following table:

Design Flow	Minimum Grease Trap
Up to 1000 gpd	8' dia. - 5' liquid depth
1000 - 4000 gpd	10' dia. - 5' liquid depth
Greater than 4000 gpd	12' dia. - 5' liquid depth

Discharges from grease traps may not be routed to modified sewage disposal systems (denitrification). In cases where a modified sewage disposal system is proposed, the discharge from a grease trap shall be routed to a separate conventional subsurface sewage disposal system. Duplicate internal disposal piping systems are required for shopping centers where food service establishments may be placed.

Grease traps should be cleaned and maintained on a regular basis in order to insure proper functioning and insect free performance.

17. LEACHING POOLS

Leaching pool systems (Figures 5, 6, and 7) shall be designed on the basis of sidewall area to receive the full day's design flow. The minimum system sidewall leaching area is 300 sq. ft. The sidewall leaching area is computed from the outside wall area below the inlet pipe. A maximum hydraulic leaching rate of 1.5 gal/sq ft/day is to be used for conventional subsurface sewage disposal systems. For other leaching rates see the appendices. The pool bottom area is not to be included in the leaching area computation. The bottom of any leaching pool shall be at least two feet above the highest recorded groundwater level at the proposed system's location. Leaching pools shall be installed with traffic bearing slabs or domes and cast iron covers at grade over the manhole allowing for easy access.

When the sewage disposal system consists of less than five leaching pools, the leaching pools can be piped directly from the septic tank. When five leaching pools or more are required, a distribution leaching pool shall be used to apportion the flow to the other leaching pools. When a distribution pool is used, all outlet inverts shall be set at the same elevation and be at least three inches below the inlet invert. All outlets shall be provided with 18-inch drop 'T's. In all cases, unsuitable soils shall be removed and replaced with clean, coarse sand and gravel conforming to criteria as set forth in Section A4 of Appendix A for a diameter six feet greater than the leaching pool (three foot collar) extending down into a minimum six foot strata of virgin sand and gravel. In those areas where these criteria cannot be met, consult the department. The use of any sewage disposal system other than the basic systems requires separate approval by the department. The following additional criteria apply to the design and construction of leaching pools:

1. Leaching pools are to be constructed of reinforced precast concrete sanitary leaching rings, solid domes and/or traffic bearing slabs.
2. All leaching pools shall be between eight feet and ten feet in diameter.

3. When more than one leaching pool is used, all pools shall be the same size, except the distribution pool which may differ in size.
4. Access openings with a minimum diameter of twenty inches shall be provided for each pool.
5. Leaching pools, including distribution pools, shall be equipped with insect and waterproof cast iron covers at final grade.
6. Leaching pool chimneys shall be of reinforced precast concrete and may not exceed two feet in height.
7. The maximum permissible depth of a precast concrete leaching pool is twenty-five feet below grade.
8. The effective leaching area of a leaching pool (below the inlet pipe) shall be entirely in virgin sand and gravel, or be installed in replacement soils as stated above.
9. The bottom and sidewall area of the leaching pools shall be free of debris before backfilling.

18. MANHOLES

Manholes shall be provided on sewer lines wherever there is a grade change or alignment change further than ten feet from the foundation and otherwise at intervals not exceeding 400 feet. Manholes are not used on force mains. The following additional criteria apply to the design and construction of manholes.

1. The bottom of the manhole shall be coved or benched. The bench shall be the same width as the diameter of the pipe and shall extend upward at least three-quarters of the diameter of the pipe.
2. The manhole shall have a minimum inside diameter of four feet and be reinforced precast concrete only.
3. The base and walls of the manhole shall be monolithically constructed of reinforced precast concrete.
4. There shall be a flexible coupling located within four feet of the manhole on both the inlet and outlet side. For PVC pipe, a flexible connection of a type approved by the department is acceptable at the manhole penetration.
5. If the manhole is more than four feet in depth, aluminum rungs shall be provided every twelve inches.
6. The manhole shall be provided with a twenty-four inch diameter, insect and waterproof cast-iron cover to grade, located so as to be over the rungs if any are necessary. The cover shall have the word "SANITARY" cast into it.
7. For sewer lines connecting to community sewerage systems, the house connection shall not be piped directly to a manhole. Consult the proper sewer authority for other design criteria.

19. GRAVITY SEWER LINES

1. All gravity sewer lines shall be a minimum of four inches in diameter.

2. There shall be a minimum two foot length of cast-iron sewer line extending through the foundation.
3. The sewer line from the building cast-iron pipe to the septic tank and to the leaching pool(s) shall meet or exceed ASTM standards for plastic sewer pipe with a minimum SDR 35 rating. Consult Appendix E and town plumbing codes for further piping requirements.
4. Slip-ring connectors of the proper type shall be used at the cast-iron joint.
5. The sewer line from the building to the septic tank and/or grease trap shall have a minimum pitch of one-quarter inch per foot.
6. The sewer line from the septic tank to the leaching pool(s) shall have a minimum pitch of one-eighth inch per foot.
7. Sewer line trench(es) shall be firmly tamped. All backfill shall be firmly tamped about the pipe by means of a hand held device. The pipe(s) shall be securely cemented at the point of entry into the septic tank and leaching pool(s).
8. There shall be no bends in the sewer lines to the septic tank. If bends are unavoidable, then, for bends within the first ten feet from the building foundation, the sewer line shall be constructed of cast-iron from the building foundation up to and including the bend and provided with a cleanout. Long sweep elbows shall be used and bends shall not exceed forty-five degrees as measured along the axis of the starting pipe. For bends further than ten feet from the building foundation an approved manhole shall be installed. For projects with a large number of bends consult the department prior to installation.
9. All sewer lines shall be straight. When sections of pipes are used, they shall be connected with couplings of the same material. The couplings shall be securely installed and watertight.
10. Sewer line materials shall not be intermixed.
11. When using more than one leaching pool, all sewer lines from the septic tank to the pools shall be set in the septic tank at the same elevation.
12. Multi-family buildings with individually owned dwelling units shall be equipped with a separate sewer line for each dwelling unit connecting to a common sewer system.
13. House connection sewer lines shall be provided with cleanouts every 75 feet.
14. Sewer trunk lines of 6" diameter may be placed at 1% slope. Sewer trunk lines of 8" diameter may be placed at 0.4% slope. Cleanouts shall be provided every 75 feet unless a manhole is utilized.

20. SEPARATION OF WATER AND SEWER LINES

A. PARALLEL INSTALLATION

1. Water lines shall be laid at least ten feet horizontally from any sewer line.

2. When local conditions prevent a horizontal separation of ten feet, a water line may be laid closer to a sewer line provided that the bottom of the water line is at least eighteen inches above the top of the sewer line. When this vertical separation cannot be obtained, the sewer line shall be constructed of materials and joints that are equivalent to water main standards of construction and shall be pressure tested to assure water tightness prior to backfilling.

B. CROSSINGS

1. The crossing of water and sewer lines should be avoided unless proven absolutely necessary. In such cases:
 - a) sewer lines shall be laid below the water line and provide a separation of at least eighteen inches between the bottom of the water line and the top of the sewer line; and
 - b) sewer line joints shall be at least ten feet from the point of crossing.
2. When local conditions prevent placement of the water line above the sewer line, the following additional conditions apply:
 - a) a vertical separation of at least eighteen inches shall be provided between the bottom of the sewer line and the top of the water line; and
 - b) water line joints shall be at least ten feet from the point of crossing; and
 - c) sewer lines shall be constructed of materials and joints that are equivalent to water main standards of construction and shall be pressure tested to assure watertightness prior to backfilling.

21. FINAL GRADING AND BACKFILLING

At the time of completion, the system shall be left visible for inspection. Prior to inspection, the bottom of the pipe trench shall be backfilled with granular material and stabilized to provide a firm bedding. The property lines shall be "staked" in order to ascertain that the system is located on the property in accordance with these standards.

The completed system shall be backfilled and covered with suitable soil following permission to do so by the Department. The property shall be graded so as to minimize surface drainage into the system. A maximum five percent slope shall be maintained for a minimum of twenty feet horizontally from the nearest edge of the leaching pool(s) before tapering off to prevent seepage of the leachate through the toe or edge of the slope. Steep grades further than twenty feet from the leaching pools shall be stabilized to prevent erosion.

In cases where the maximum five percent slope cannot be maintained, the utilization of retaining walls, or other means, may be approved. In such cases, the retaining walls, or other means, shall be designed by a licensed professional engineer or registered architect and be shown as part of a grading and plot plan. The plan shall be reviewed and approved by the department prior to construction.

Retaining walls shall be designed in accordance with good engineering practice and applicable building codes. In addition, retaining walls cannot be closer than ten feet from the nearest part of the sewage disposal system. Retaining walls within twenty feet of a leaching pool(s) shall be waterproof.

22. SEWAGE LIFT STATIONS

All conventional sewage disposal systems should be designed to flow by gravity. Only when absolutely necessary should pumps be used. In such cases, a lift station shall be designed by a licensed professional engineer or registered architect, and plans must be reviewed and approved by the department prior to construction.

Minimum requirements shall include:

1. Dual submersible pump system with easy access and removal;
2. High-level alarm with interlock to annunciate upon startup of second (lag) pump;
3. Electronic control to alternate pump selected as lead pump;
4. Freeze protection;
5. For sizing requirements consult the Department.

For information on pump stations for treatment works, or large collection systems, see **Ten States Standards** and Appendix B.

23. VARIANCES

- A. The Commissioner of the Department of Health Services, on written application, may grant a variance, in accordance with Section 220 of Article 2 of the Suffolk County Sanitary Code, from a specific provision of these Standards in a particular case, subject to appropriate conditions, where such variance is in harmony with the general purpose and intent of the Standards, and when such application for a variance has been considered by a Review Board appointed by the Commissioner.
- B. The Commissioner may impose more stringent requirements in a specific case when necessary to insure an adequate and satisfactory sewage and waste disposal system.

24. APPROVAL BY THE COMMISSIONER OF HEALTH SERVICES

In accordance with Section 221, Article 2, of the Suffolk County Sanitary Code, the foregoing are Standards for Approval of Plans And Construction For Sewage Disposal Systems for Other Than Single Family Residences approved by the Suffolk County Commissioner of Health Services and include the required details for submission of plans and other information to the Suffolk County Department of Health Services to assure conformity to the approved Standards. These Standards are effective _____.

Mary E. Hibberd, M.D., M.P.H.
Commissioner of Health Services
County of Suffolk

25. COMMERCIAL SEWAGE DESIGN FLOWS -- ADDENDUM

	<u>SANITARY</u>	<u>KITCHEN/GREY</u>	<u>TOTAL</u>
Firehouse	0.03 gpd/sf	N/A	0.03 gpd/sf
Library	0.03 gpd/sf	N/A	0.03 gpd/sf
Greenhouse	0.04 gpd/sf	N/A	0.04 gpd/sf
Drug Rehabilitation	75 gpd/bed	N/A	75 gpd/bed
Counseling Center (non-medical)	12 gpd/occupant plus 5 gpd/visitor	N/A	12 gpd/occupant plus 5 gpd/visitor
Mental Health Residence	75 gpd/bed	N/A	75 gpd/bed
Funeral Home	0.05 gpd/sf	N/A	0.05 gpd/sf
Marina	10 gpd/boatslip		10 gpd/boatslip
Ice Skating Rink	15 gpd/skater plus 5 gpd/spectator		15 gpd/skater plus 5 gpd/spectator plus food service
Miniature Golf	15 gpd/parking space	N/A	15 gpd/parking space
Car Wash	0.04 gpd/sf	N/A	0.04 gpd/sf (excluding car wash processing water)
Restaurant	10 gpd/seat	20 gpd/seat	30 gpd/seat
Takeout Max. 16 seats & Single Service	0.03 gpd/sf	0.12 gpd/sf	0.15 gpd/sf
Bar	10 gpd/occupant	5 gpd/occupant	15 gpd/occupant plus food service
Catering Hall	5 gpd/seat	2.5 gpd/seat	7.5 gpd/seat
Outside Patio Dining	5 gpd/seat	10 gpd/seat	15 gpd/seat
Cafeteria (in building) not open to public	N/A	2.5 gpd/person	2.5 gpd/person
Lunch Program	5 gpd/person	2.5 gpd/person	7.5 gpd/person
Convenience Store	0.03 gpd/sf	0.02 gpd/sf	0.05 gpd/sf
Wet Store, No Food (barber shop, etc.)	0.03 gpd/sf	0.07 gpd/sf	0.10 gpd/sf
Fitness Centers/Karate/Dance/etc. w/ showers and other amenities	0.10 gpd/sf	0.20 gpd/sf	0.30 gpd/sf
Fitness Centers/Karate/Dance/etc. w/o showers and other amenities	0.10 gpd/sf	N/A	0.10 gpd/sf

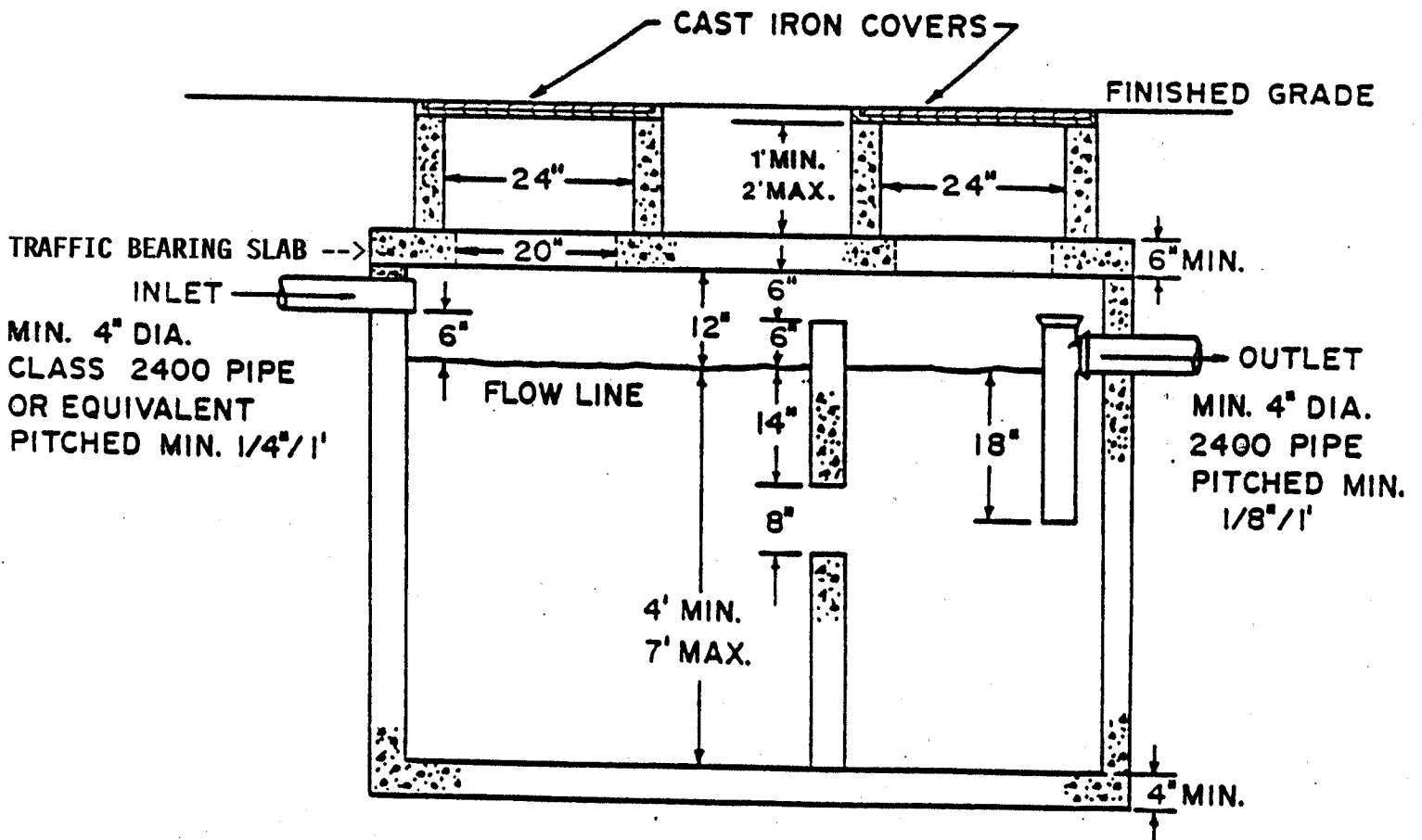
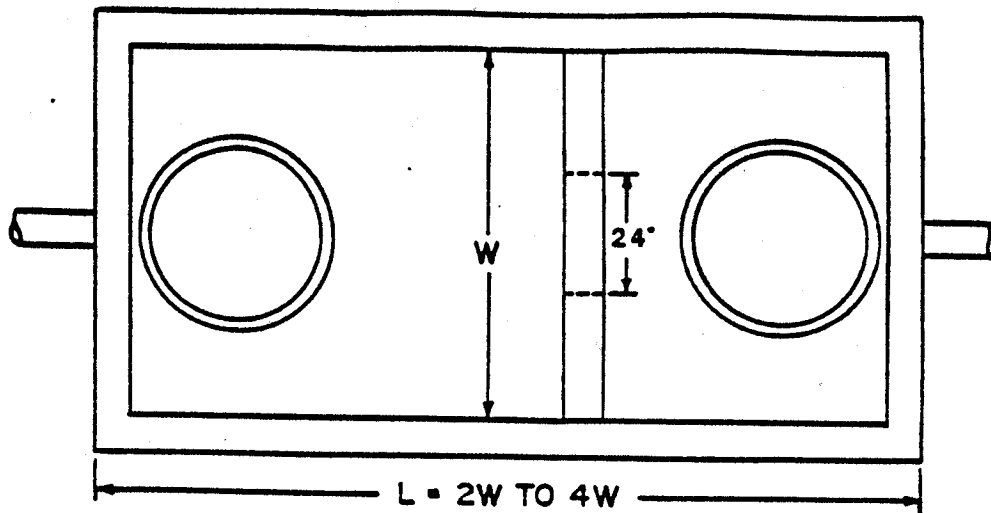

FIGURE 1
RECTANGULAR SEPTIC TANK

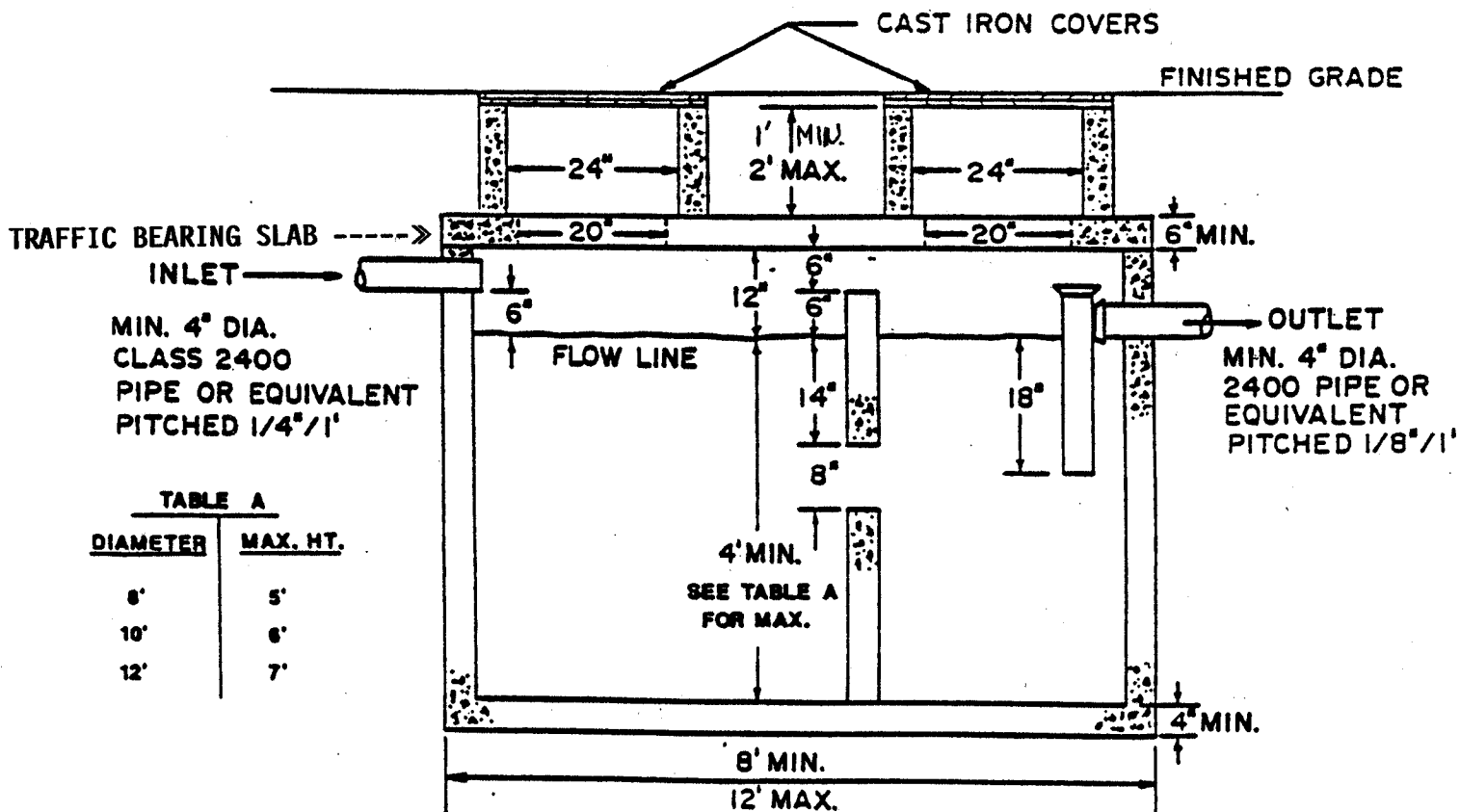
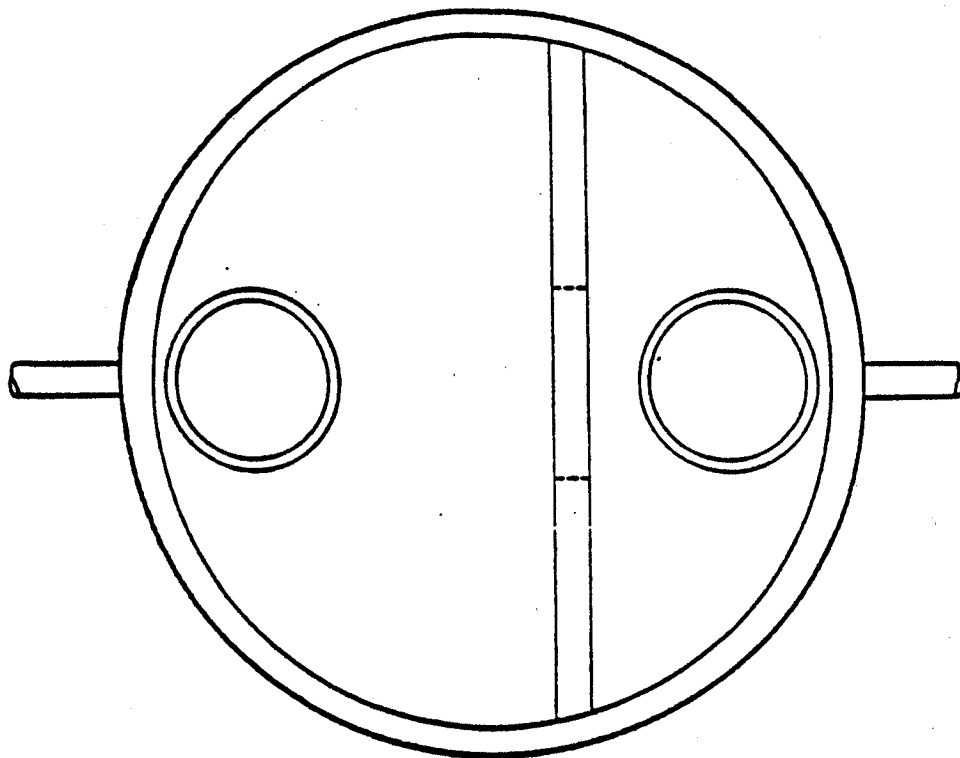
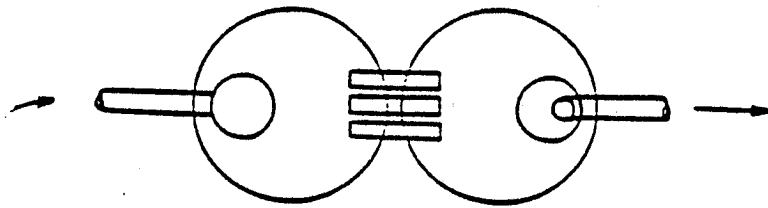

TABLE A

DIAMETER	MAX. HT.
8'	5'
10'	6'
12'	7'

FIGURE 2
CYLINDRICAL SEPTIC TANK



DETAILS:

- 1.) THREE OR MORE COMPARTMENT SEPTIC TANKS SHALL BE CONSTRUCTED ON A COMMON REINFORCED CONCRETE SLAB AT LEAST 6 INCHES THICK.
- 2.) EACH COMPARTMENT SHALL BE CONSTRUCTED OF REINFORCED PRECAST CONCRETE SOLID RINGS, SOLID DOMES OR SLAB TOPS.
- 3.) CROSSOVER PIPES MUST BE OF 8 INCH O.D. PIPE, 20 INCHES ON CENTER, WITH CENTER LINE 18 INCHES BELOW THE LIQUID LEVEL

- 4.) WHEN USING 3 OR MORE COMPARTMENTS, THE INLET FLOW MUST BE SPLIT USING A MINIMUM 4 FOOT DIAMETER MANHOLE.
- 5.) COVERS OVER INLET/OUTLET FOR SLAB TOPS OR IN CENTER FOR DOME TOPS.

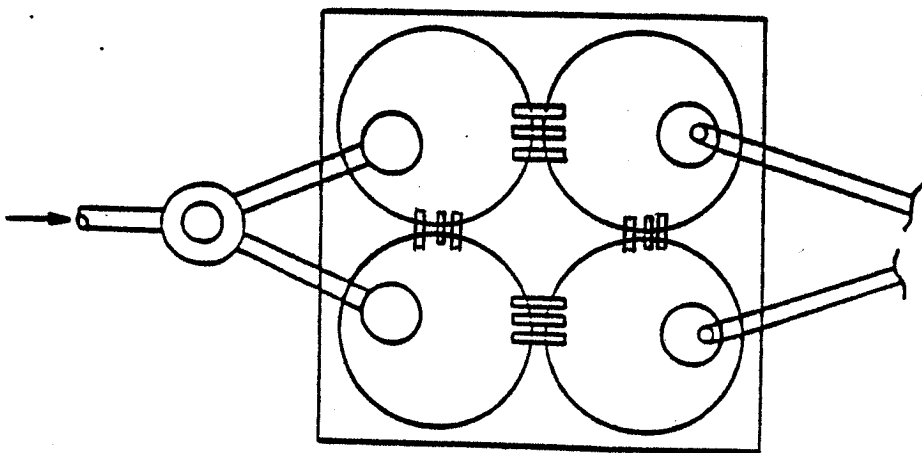
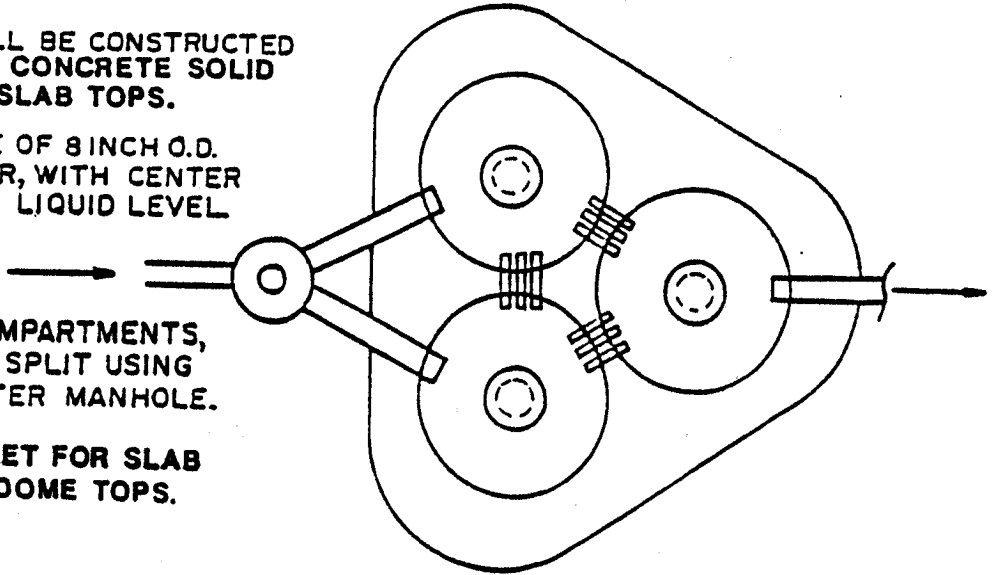
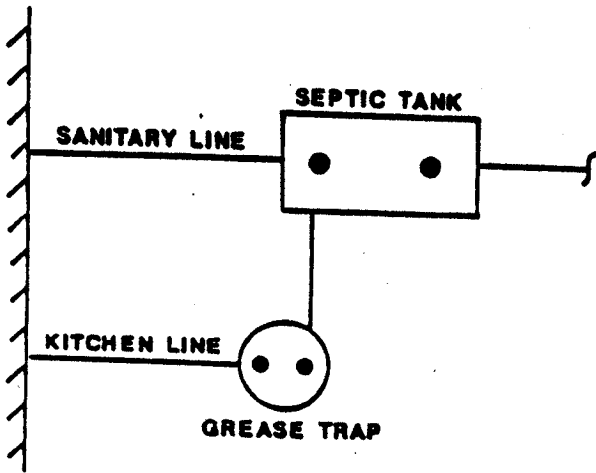
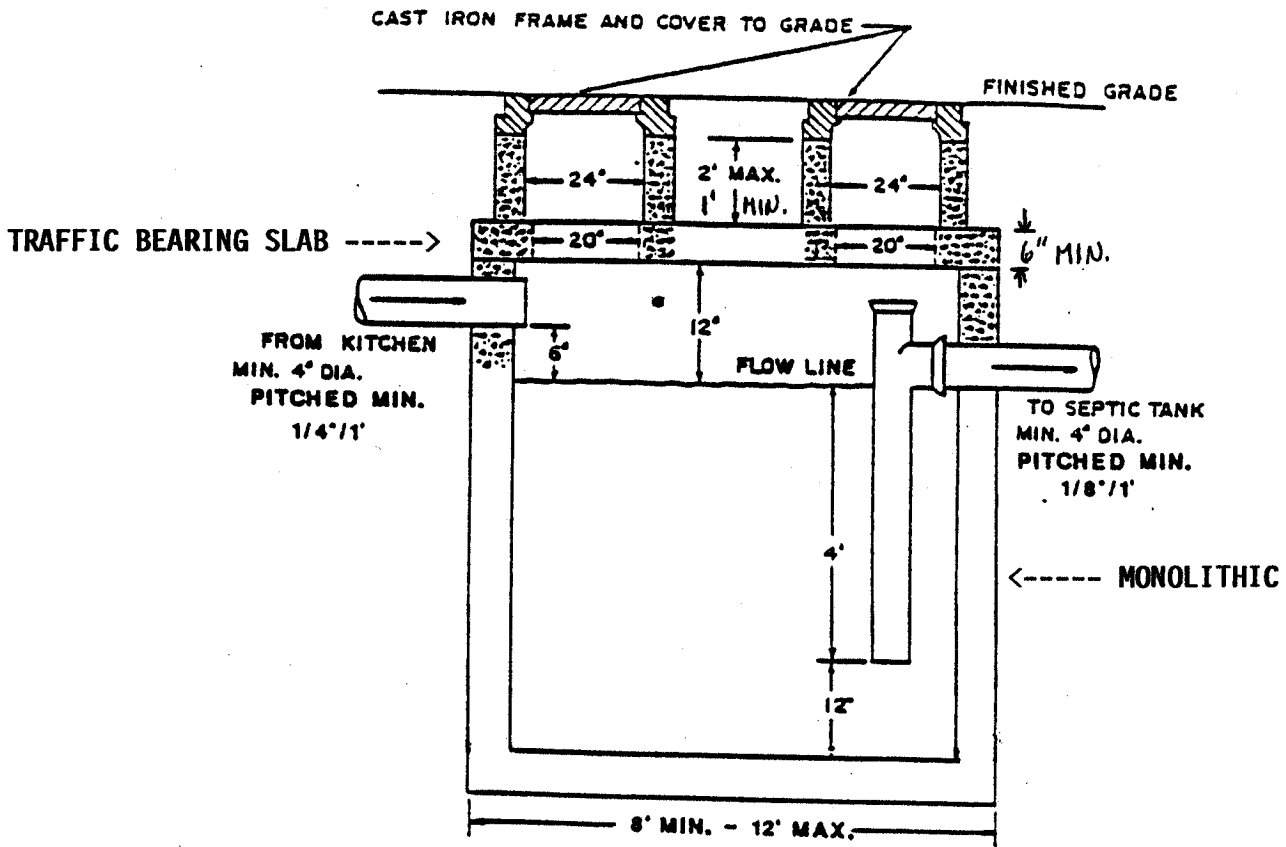
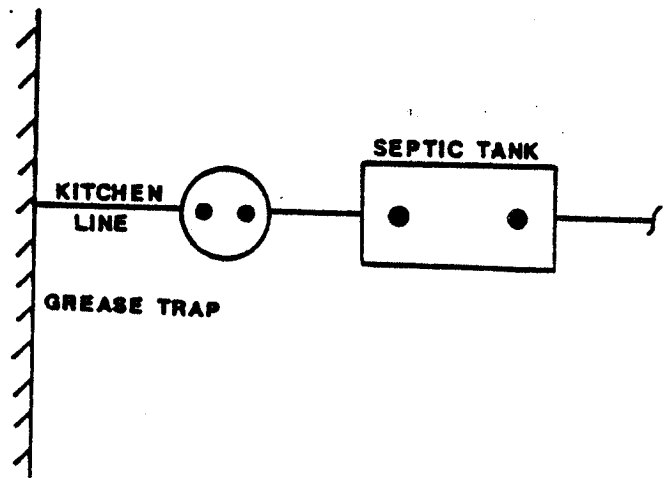

FIGURE 3
MULTI COMPARTMENT SEPTIC TANK



COMBINED SYSTEMS



KITCHEN ONLY SYSTEMS

FIGURE 4
TYPICAL GREASE TRAP & ARRANGEMENTS

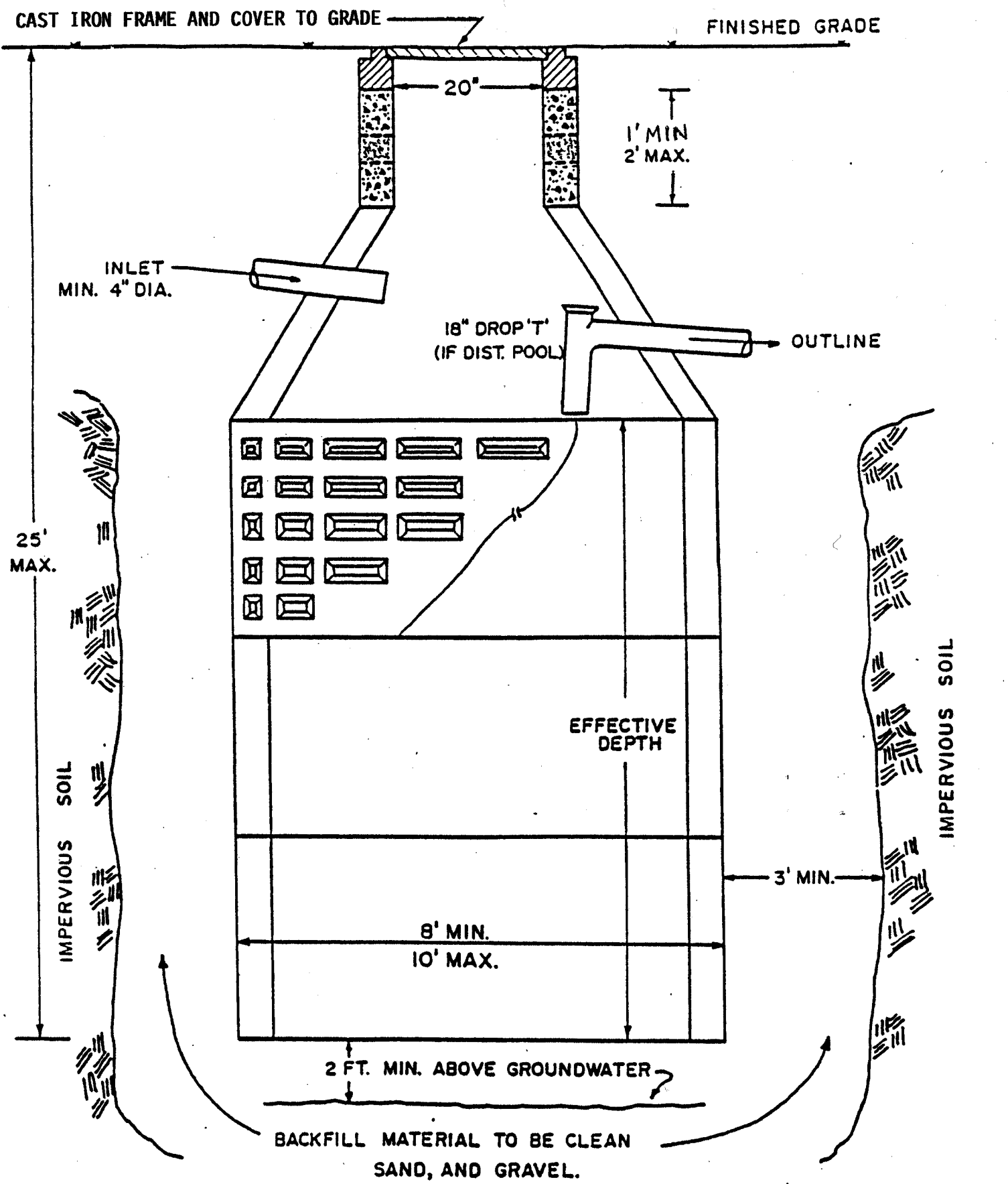
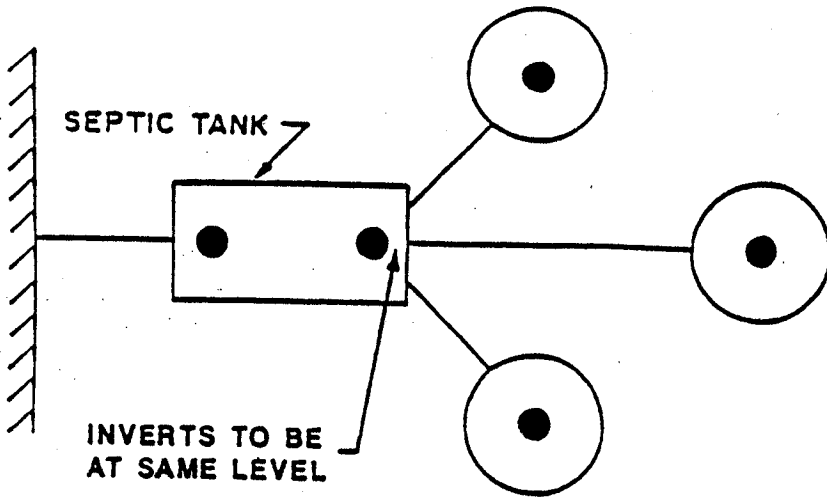

FIGURE 5
TYPICAL LEACHING POOL

ANY COMMERCIAL BLDG.



WHEN USING 1, 2, OR 3 LEACHING POOLS EACH POOL RECEIVES AN INDIVIDUAL PIPE FROM THE SEPTIC TANK.

ANY COMMERCIAL BLDG.

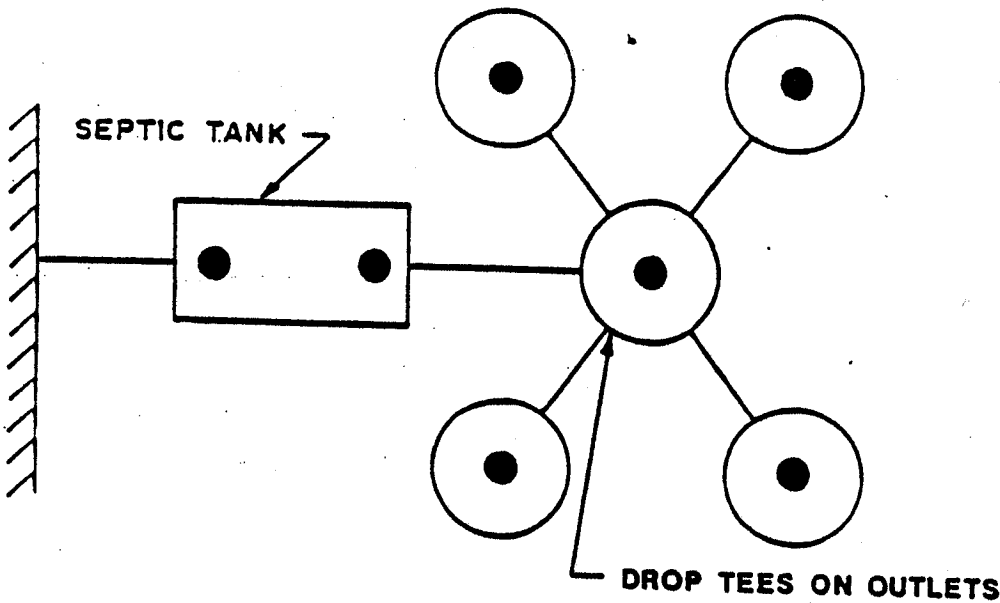

WHEN USING 4 OR MORE LEACHING POOLS A DISTRIBUTION LEACHING POOL MUST BE USED TO SPLIT THE FLOW EVENLY TO THE REMAINING LEACHING POOLS. NO MORE THAN 4 POOLS MAY BE ATTACHED TO A SINGLE DISTRIBUTION POOL.

FIGURE 6
MULTIPLE LEACHING POOL DESIGNS

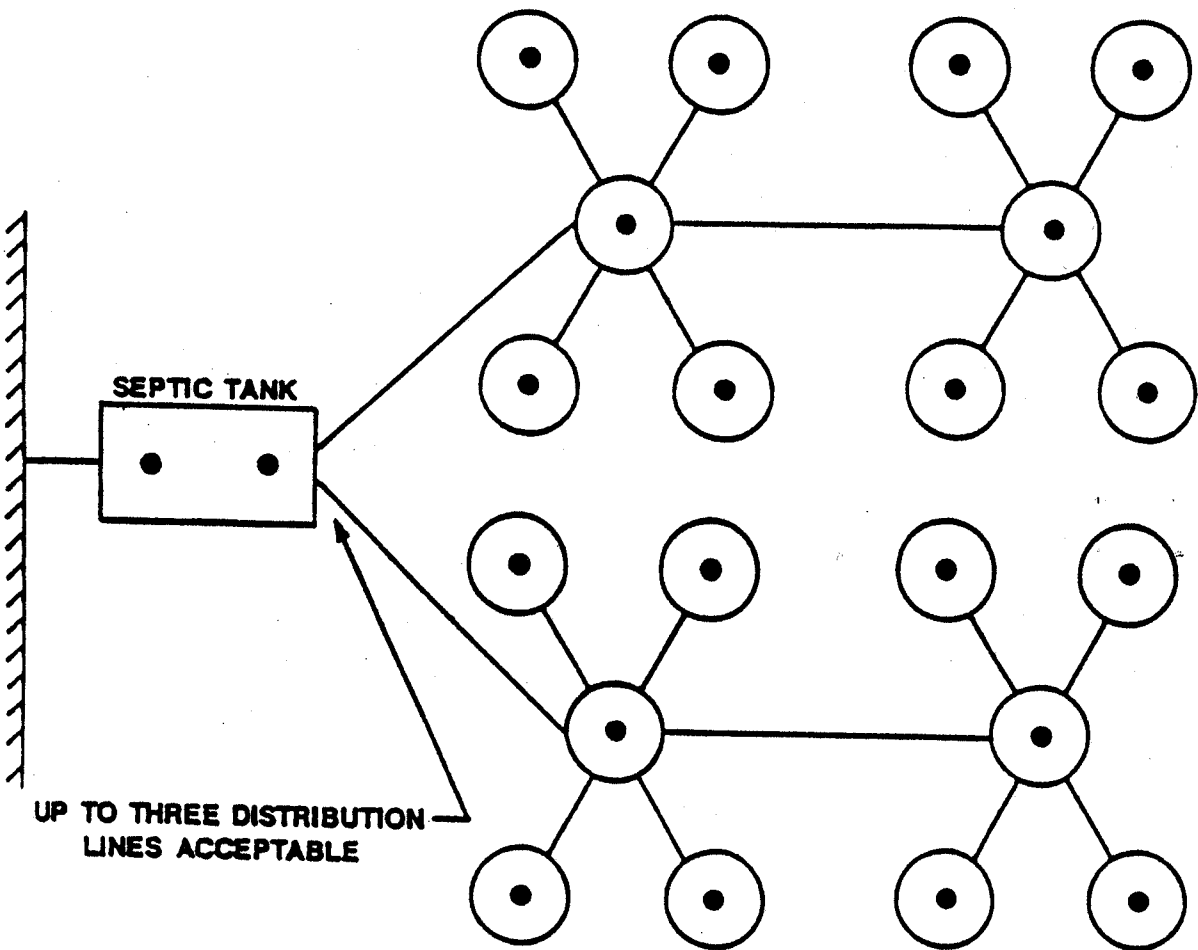
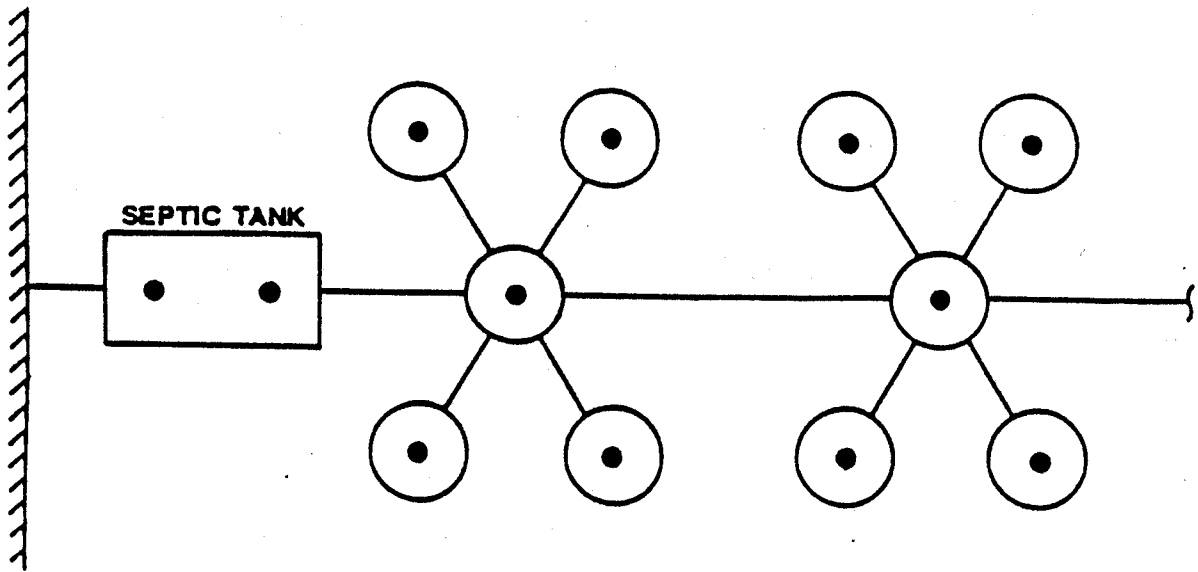

UP TO THREE DISTRIBUTION
LINES ACCEPTABLE

FIGURE 7
RECOMMENDED MULTIPLE LEACHING POOL ARRANGEMENTS